

PRODUCT INFORMATION PACKET

marathon[®]
Motors

Model No: 365TTFS14071
Catalog No: Y1627
75,1800,TEFC,365T,3/60/230/460
Fire Pump



Regal and Marathon are trademarks of Regal Beloit Corporation or one of its affiliated companies.
©2018 Regal Beloit Corporation, All Rights Reserved. MC017097E

REGAL[®]



Nameplate Specifications

Output HP	75 Hp	Output KW	56.0 kW
Frequency	60 Hz	Voltage	230/460 V
Current	176.0/88.0 A	Speed	1778 rpm
Service Factor	1.15	Phase	3
Efficiency	94.1 %	Duty	Continuous
Insulation Class	F	Design Code	B
KVA Code	G	Frame	365T
Enclosure	Totally Enclosed Fan Cooled	Overload Protector	No
Ambient Temperature	40 °C	Drive End Bearing Size	6314
Opp Drive End Bearing Size	6312	UL	No
CSA	Y	CE	Y
IP Code	43		

Technical Specifications

Electrical Type	Squirrel Cage Induction Run	Starting Method	Part Wdg Start Low Volt Only & Wye Start Delta Run
Poles	4	Rotation	Reversible
Mounting	Rigid base	Motor Orientation	Horizontal
Drive End Bearing	Ball	Opp Drive End Bearing	Ball
Frame Material	Cast Iron	Shaft Type	T
Overall Length	32.52 in	Frame Length	14.50 in
Shaft Diameter	2.375 in	Shaft Extension	6.13 in
Assembly/Box Mounting	F1/F2 Capable		
Outline Drawing	B-SS504688-1450	Connection Diagram	A-EE7308AA

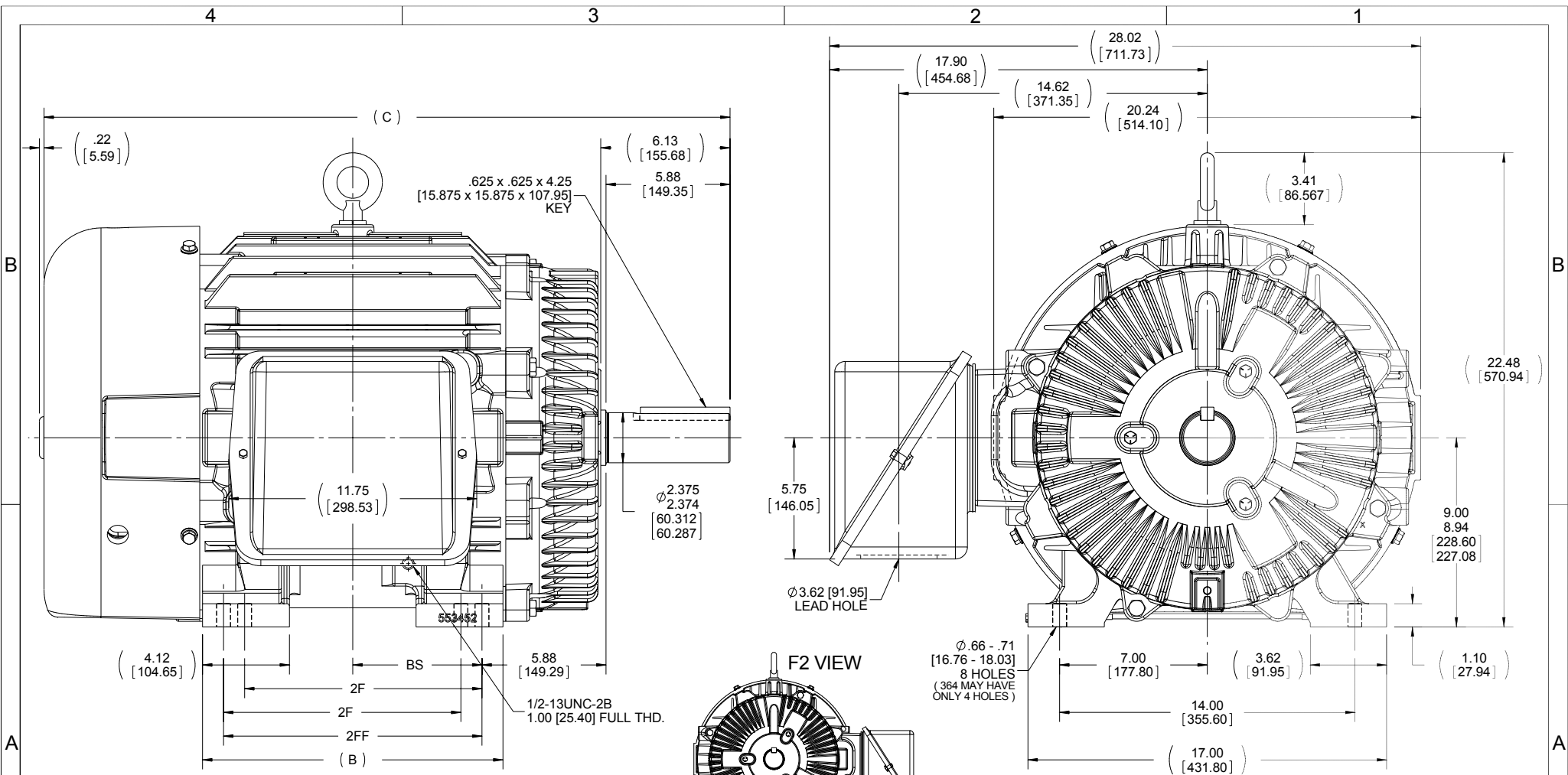

- NOTES:
 1. CONDUIT BOX CAN BE ROTATED IN 90° STEPS.
 2. CONDUIT BOX CAN BE MOUNTED ON OPPOSITE SIDE BY REMOVING BRACKETS AND TURNING FRAME 180°.
 3. NAMEPLATES TO BE READ FROM CONDUIT BOX SIDE OF MOTOR.

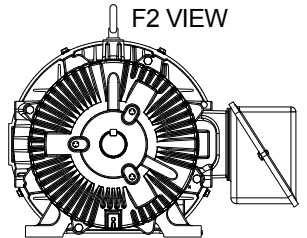

DASH	FRAME	B	C	2F	2FF	BS
1350	364T	13.25 [336.55]	31.52 [800.61]	11.25 [285.75]	---	5.62 [142.75]
1450	364/365T	14.25 [361.95]	32.52 [826.01]	11.25 [285.75]	12.25 [311.15]	6.12 [155.45]

DRAWING REVISION D	REVISION BY JHA	DATE 02-03-2016
ECO ECO-0092438	APPROVED BY TDB	DATE 02-03-2016
ECO DESCRIPTION UPDATED TO CURRENT STANDARDS		
<small>COPYRIGHT REGAL BELOIT AMERICA, INC. ALL RIGHTS RESERVED. PROPRIETARY AND CONFIDENTIAL INFORMATION - THIS DOCUMENT IS THE PROPERTY OF REGAL BELOIT AMERICA, INC. (OWNER) AND CONTAINS OWNER'S PROPRIETARY INFORMATION. ANY PERSON, CORPORATION OR OTHER FIRM RECEIVING IT IS DEEMED, BY RECEIVING IT, TO AGREE THAT IT, AND/OR ANY PART OF IT, SHALL NOT BE DISCLOSED TO ANY PERSON, CORPORATION OR OTHER ENTITY, DUPLICATED, AND/OR USED, EXCEPT AS EXPRESSLY APPROVED IN WRITING IN ADVANCE BY OWNER. THIS DOCUMENT SHALL BE RETURNED TO OWNER UPON REQUEST. IT MAY BE SUBJECT TO CERTAIN RESTRICTIONS UNDER APPLICABLE EXPORT CONTROL LAWS AND REGULATIONS.</small>		

TOLERANCES UNLESS OTHERWISE SPECIFIED:		
DEC.	INCH	mm
-X	+0.1	[+2.5]
.XX	+0.03	[+0.76]
.XXX	+0.005	[+0.127]
.XXXX	+0.0005	[+0.0127]
REMOVE BURRS & BREAK SHARP		
EDGES: .003/.015 [0.076/.381] X 45°		
CORNER FILLETS: R.02 [51]		
MACHINED SURFACES: 200		
INCH 5.1		
mm SHOWN IN [BRACKETS]		

DRAWN BY TLB
DATE 04-29-1998
APPROVED BY ML
DATE 04-29-1998
REFERENCE
THIRD ANGLE PROJECTION

Regal Beloit America, Inc.	
DESCRIPTION OUTLINE 360T FR. - TEFC - (STD.)	
MATERIAL	PROCESS/FINISH
SIZE B	DRAWING NUMBER SS504688
	SHEET 1 OF 1



LOW VOLTAGE



HIGH VOLTAGE



DRAWING REVISION K	REVISION BY AJW	DATE 07-17-2015
ECO ECO-0081632	APPROVED BY T. VUE	DATE 07-17-2015
ECO DESCRIPTION REV'D IEC MARKINGS PER IEC 60034-8		
<small>COPYRIGHT REGAL BELOIT AMERICA, INC. ALL RIGHTS RESERVED. PROPRIETARY AND CONFIDENTIAL INFORMATION - THIS DOCUMENT IS THE PROPERTY OF REGAL BELOIT AMERICA, INC. ("OWNER") AND CONTAINS OWNER'S PROPRIETARY INFORMATION. ANY PERSON, CORPORATION OR OTHER FIRM RECEIVING IT IS DEEMED, BY RECEIVING IT, TO AGREE THAT IT, AND/OR ANY PART OF IT, SHALL NOT BE DISCLOSED TO ANY PERSON, CORPORATION OR OTHER ENTITY, DUPLICATED, AND/OR USED, EXCEPT AS EXPRESSLY APPROVED IN WRITING IN ADVANCE BY OWNER. THIS DOCUMENT SHALL BE RETURNED TO OWNER UPON REQUEST. IT MAY BE SUBJECT TO CERTAIN RESTRICTIONS UNDER APPLICABLE EXPORT CONTROL LAWS AND REGULATIONS.</small>		

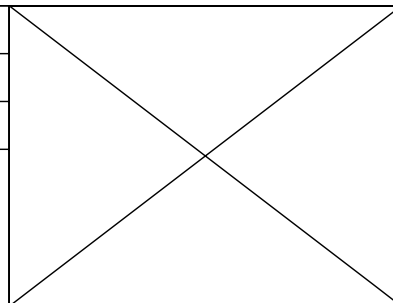

DRAWN BY LZ	Regal Beloit America, Inc.	
DATE 01-12-1994		
APPROVED BY GK	DESCRIPTION CONN DIAGRAM-EXTERNAL 3Ø-2/1 DELTA-12 LEADS	
DATE 01-14-1994		
REFERENCE	MATERIAL	PROCESS/FINISH
THIRD ANGLE PROJECTION	SIZE A	DRAWING NUMBER EE7308AA
		SHEET 1 OF 1

